

## PRODUCT MANUAL

**Product: Mixing room#YFT-400**

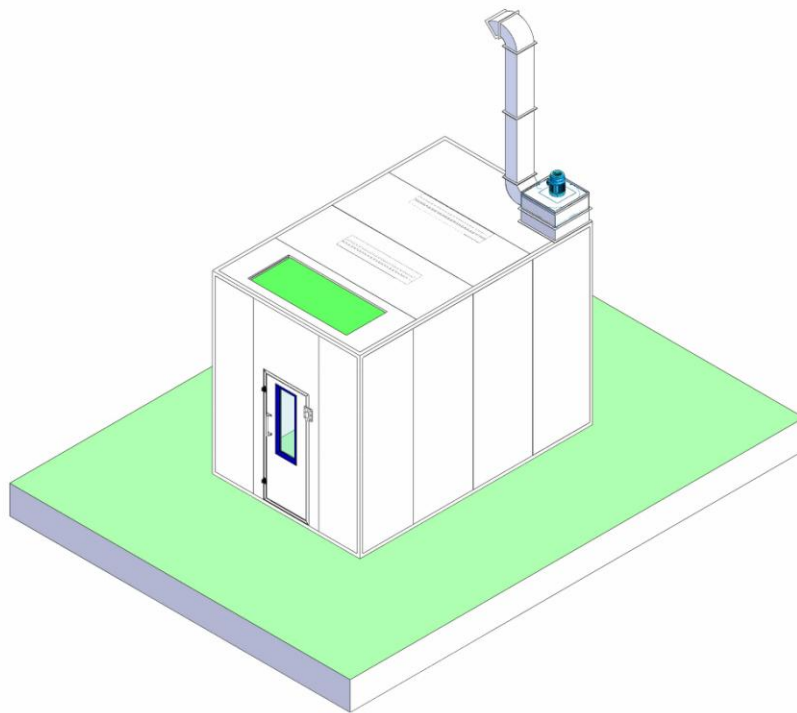

**Address: No.2, TaiGang Road, BaiYun District, Guangzhou, Guangdong, China**

**Tel: 86 - 20 - 36051789**

**Email: [fengyin@gz-infitech.com](mailto:fengyin@gz-infitech.com)**

**Fax: 86 - 20 - 36051797**

**Website: [www.yft-spraybooth.com](http://www.yft-spraybooth.com)**

## QUOTATION

### 1) PRODUCT AND PRICE

**Currency: USD**

NO.	Name	Model	Unit	QTY	Unit price	Total price
1	Mixing room	YFT-400	set	1	1,169	1,169
Total EXW price						1,169

### 2) PRICE TERMS

- Quotation is valid for 60 days.
- Terms of payment: T/T 100% in advance upon order confirmation.
- Production lead time: 25 days after signing the contract.
- Price includes 2-year warranty and service, but excluding the fare.
- Loading situation: LCL shipment.

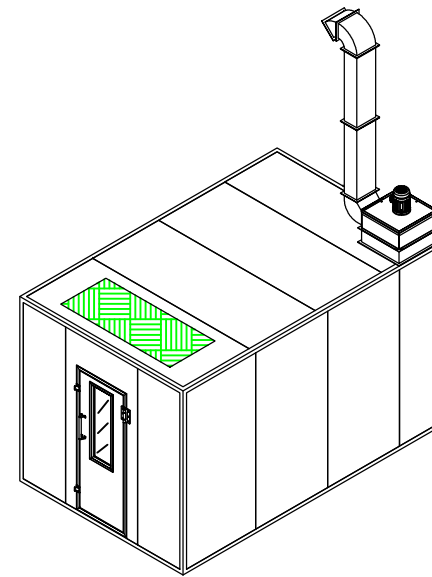
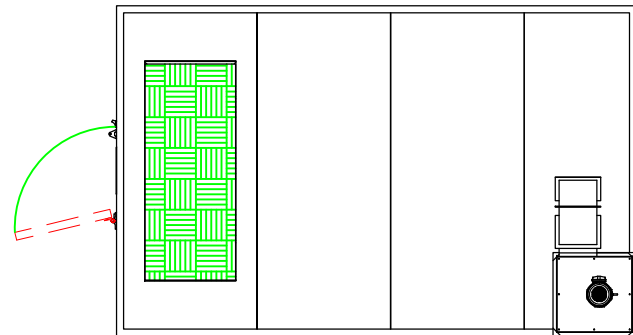
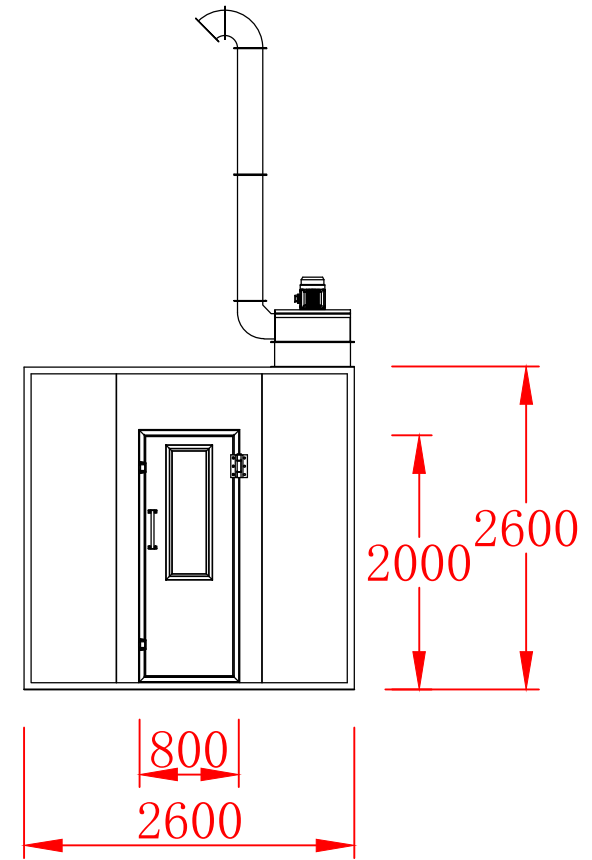
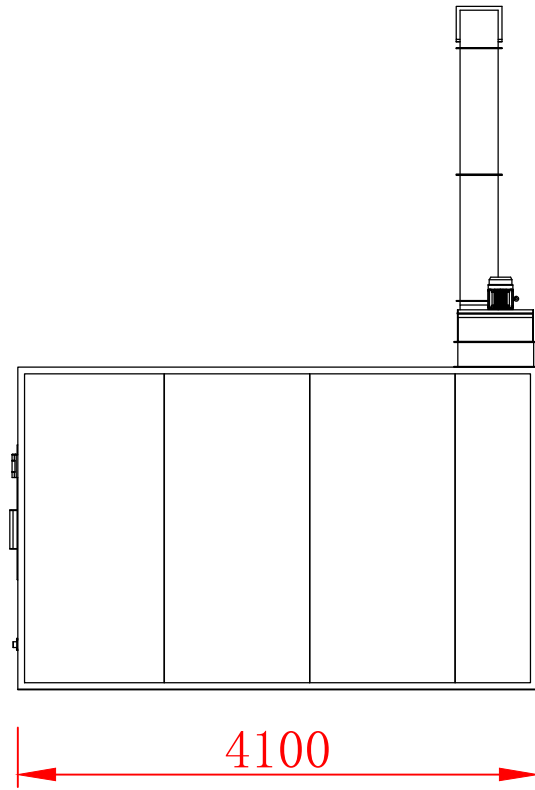

<b>INFITECH</b> <sup>®</sup>				<b>Mixing Room YFT-400</b>				<b>Product Model</b>		
								<b>Part No.</b>		
<b>Designed</b>		<b>Date:</b>		<b>Material</b>	<b>Quantity</b>	<b>Weight</b>	<b>Scale</b>	<b>Unit</b>	<b>mm</b>	
<b>Drawn</b>		<b>Date:</b>					<b>1:1</b>	<b>Revision No.</b>		
<b>Checked</b>		<b>Date:</b>		<b>View</b>		<b>Total Page</b>	<b>,Page</b>	<b>Description</b>		
<b>Approved</b>		<b>Date:</b>								

**Product: YFT-400**
**Basic information**

<b>DESIGN STANDARD</b>	BS EN 13355: 2004 + A1: 2009 BS EN 60204: 2006 + A1: 2009
<b>BOOTH DIMENSIONS</b>	
Internal dimensions	4000 X 2500 X 2500mm (L X WX H)
External dimensions	4100 X 2600 X 2550mm (L X W X H)
<b>WALL PANEL</b>	
Wall panel	50mm wall panel, wallboard filler material: heat-resistant rock wool panel
Top material	50mm wall panel, wallboard filler material: heat-resistant rock wool panel
<b>ENTRANCE DOOR</b>	
Form	Manual door
Size	800 x 2000MM(W X H)
Quantity	1 set
Door description	Containing frame, filled with heat-resistant rock wool, with safety glass observation window
<b>CEILING LIGHTING</b>	<b>(LED lamp)</b>
QTY and power	2 sets of light fixtures, each 4 X 18W, 144W total
Lighting arrangement	At the ceiling
Lighting description	Protection grade IP55
Brightness	> 800Lux
<b>FILTRATION SYSTEM</b>	
Pre-filter	Fiberglass filter cotton
Ceiling filter	N/A
Bottom paint mist collection	N/A
Exhaust filter	N/A
<b>EXHAUST SYSTEM</b>	
Exhaust fan	Direct-type turbine fan
Power and motor description	1 X 1.5KW, 1470rpm, 400V, 50 Hz, CE
Parameter of exhaust fan	5,000m <sup>3</sup> /h, 500pa
<b>PIPELINE CONFIGURATION</b>	
Straight ducting	3 pieces
90°	1 piece
Reducer	1 piece
<b>CONTROL SYSTEM</b>	
Implementation standards	Start directly
Features	Fan start, emergency stop switch, failure indication
<b>SPECIAL ITEM</b>	

## Service commitment

### Before you buy

Product quality commitment:

1. Product manufacturing and testing have quality record and testing files.
2. Product performance test. Customers will be invited to attend the complete test procedure. Once product is qualified, we will proceed with package and delivery then.

Product price commitment:

1. Use well-known raw materials to ensure high reliability and advancement of product.
2. Under the equal race condition, our company offers the most favorable price, but won't be at the cost of reducing product performance and changing product components.

### Are buying

Delivery time commitment:

Product delivery time: comply with customer's requirement. If the goods need to be finished in advance, we will arrange production and erection to satisfy the customers.

### After purchase

After purchase service commitment:

1. Service purpose: fast, decisive, exact and considerable.
2. Service target: service quality to win customer satisfaction.
3. Service principle: the warranty is 24 months, the supplier freely replaces damaged parts caused by quality reason within warranty. Beyond the warranty, the supplier provides spare parts at cost. If the equipment damages are caused by human factors, the supplier repairs or provides spare parts at cost. Our technicians will provide technical support in 24 hours upon receiving your report of the problems.

## Engineering cases

Hitachi elevator (Guangzhou) escalator Co., Ltd.



Jilin high tech Electric Vehicle Co., Ltd.



Hitachi elevator (Guangzhou) escalator Co., Ltd.



Pacoma (China) hydraulic equipment Co., Ltd.



Malaysia



Czech Republic



**Manufacturing base**

