

Minimum height beyond the roof top

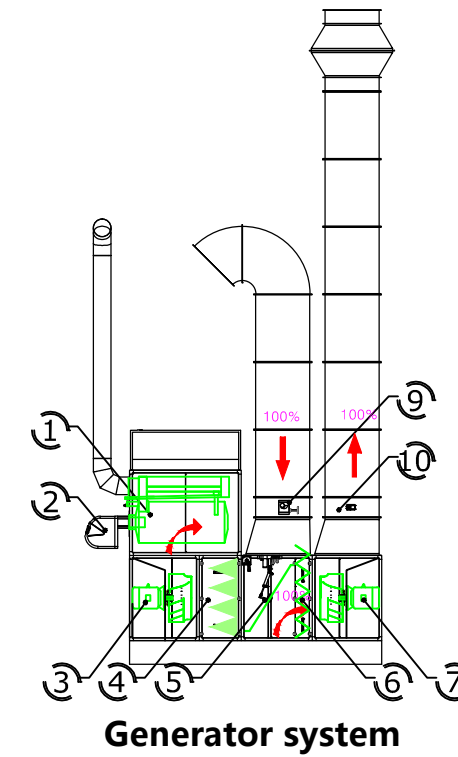

- 1.232KW SUS304 HEAT EXCHANGER
- 2.RG5D FUEL OIL BURNER
- 3.7.5KW INTAKE AIR FANS(28000m<sup>3</sup>/h , 600pa)
- 4.PREFILTRATION FILTER BAGS
- 5.CYCLE DAMPER FOR SPRAYING/OVEN PHASE
- 6.POSTFILTRATION FILTER
- 7.7.5KW OUTLET AIR FANS(28000m<sup>3</sup>/h , 600pa)
- 8.ELECTRIC POWER AND CONTROL PANEL
- 9.MANUALLY DAMPER
- 10.Electrical DAMPER

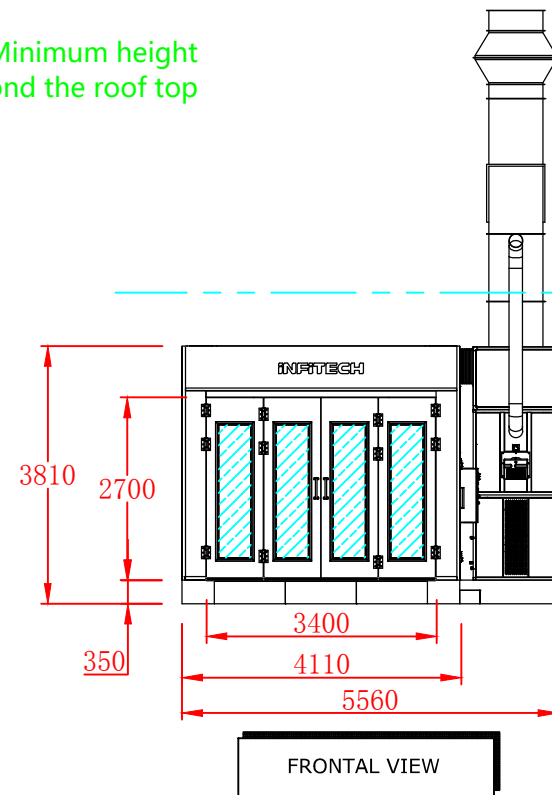
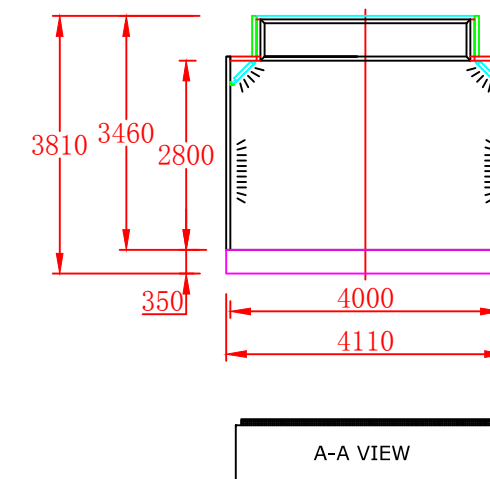
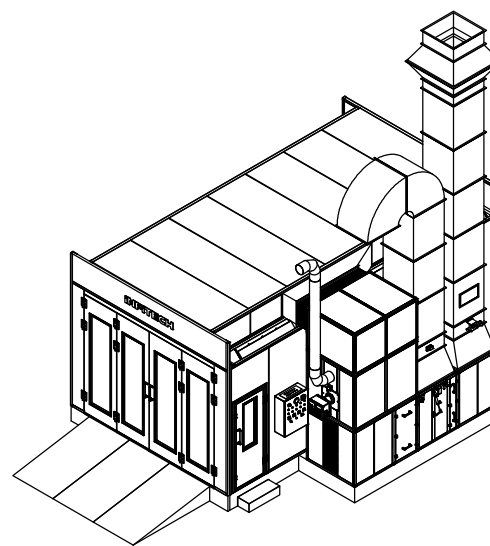
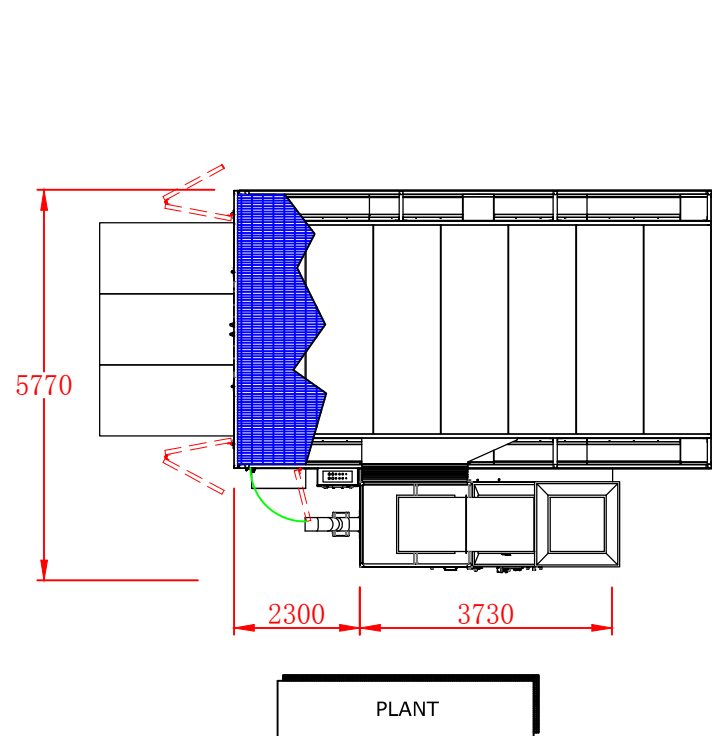

<b>INFITECH</b> <sup>®</sup>				<b>Spray Booth IT-701</b>				<b>Product Model</b>	
								<b>Part No.</b>	
<b>Designed</b>		<b>Date:</b>		<b>Material</b>	<b>Quantity</b>	<b>Weight</b>	<b>Scale</b>	<b>Unit</b>	<b>mm</b>
<b>Drawn</b>		<b>Date:</b>			<b>1</b>		<b>1:1</b>	<b>Recision No.</b>	
<b>Checked</b>		<b>Date:</b>		<b>View</b>		<b>Total Page</b>	<b>,Page</b>	<b>Description</b>	
<b>Approved</b>		<b>Date:</b>							