

Minimum height beyond the roof top

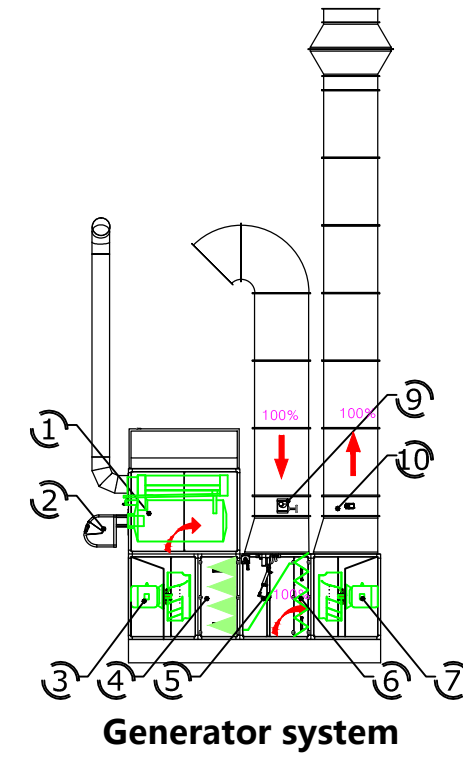

- 1.232KW SUS304 HEAT EXCHANGER
- 2.RG5D FUEL OIL BURNER
- 3.7.5KW INTAKE AIR FANS(28000m³/h , 600pa)
- 4.PREFILTRATION FILTER BAGS
- 5.CYCLE DAMPER FOR SPRAYING/OVEN PHASE
- 6.POSTFILTRATION FILTER
- 7.7.5KW OUTLET AIR FANS(28000m³/h , 600pa)
- 8.ELECTRIC POWER AND CONTROL PANEL
- 9.MANUALLY DAMPER
- 10.Electrical DAMPER

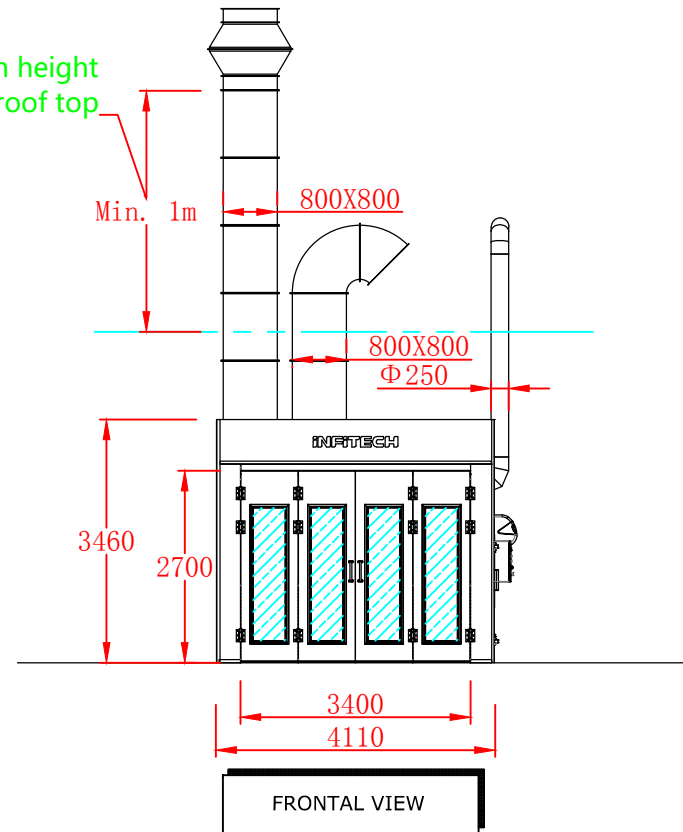
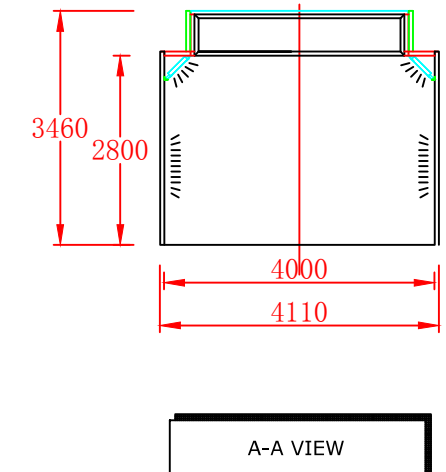
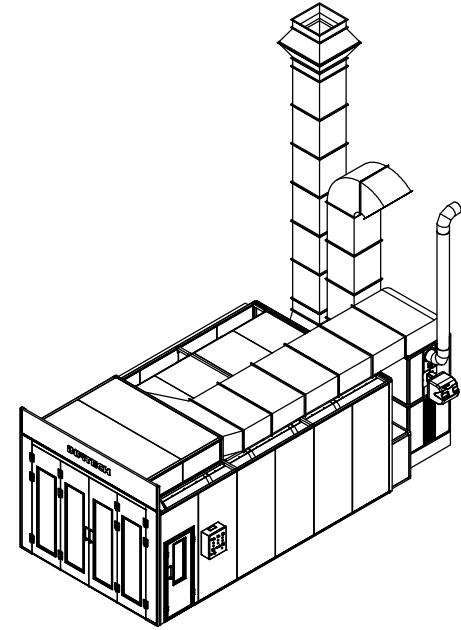
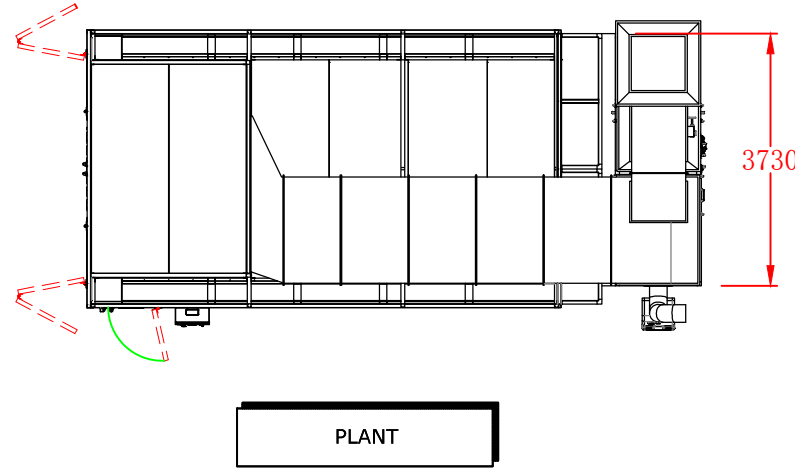

INFITECH [®]				Spray Booth IT-701-B				Product Model		
								Part No.		
Designed		Date:		Material	Quantity	Weight	Scale	Unit	mm	
Drawn		Date:			1		1:1	Recision No.		
Checked		Date:		View		Total Page	,Page	Description		
Approved		Date:								