

- 1.315KW SUS304 HEAT EXCHANGER
- 2.RL-34-2 FUEL OIL BURNER
- 3.11KW INTAKE AIR FANS(35000m³/h , 600pa)
- 4.PREFILTRATION FILTER BAGS
- 5.CYCLE DAMPER FOR SPRAYING/OVEN PHASE
- 6.POSTFILTRATION FILTER
- 7.11KW OUTLET AIR FANS(35000m³/h , 600pa)
- 8.ELECTRIC POWER AND CONTROL PANEL
- 9.MANUALLY DAMPER
- 10.Electrical DAMPER

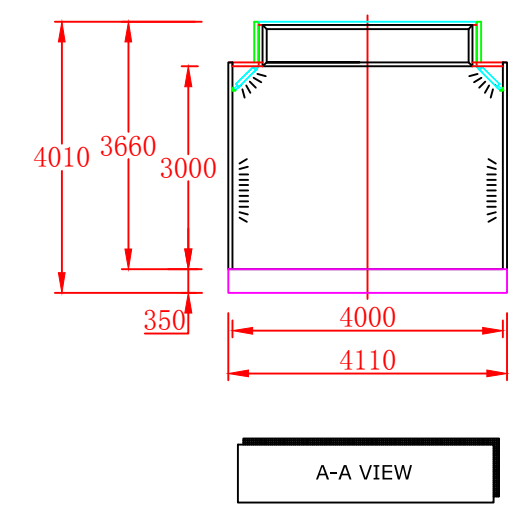
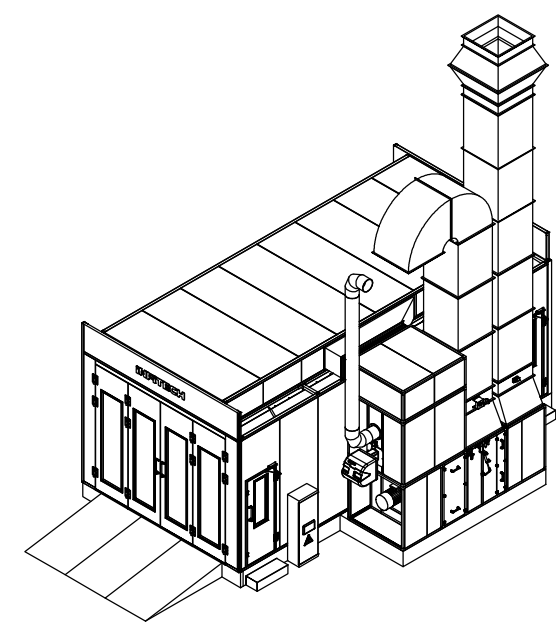
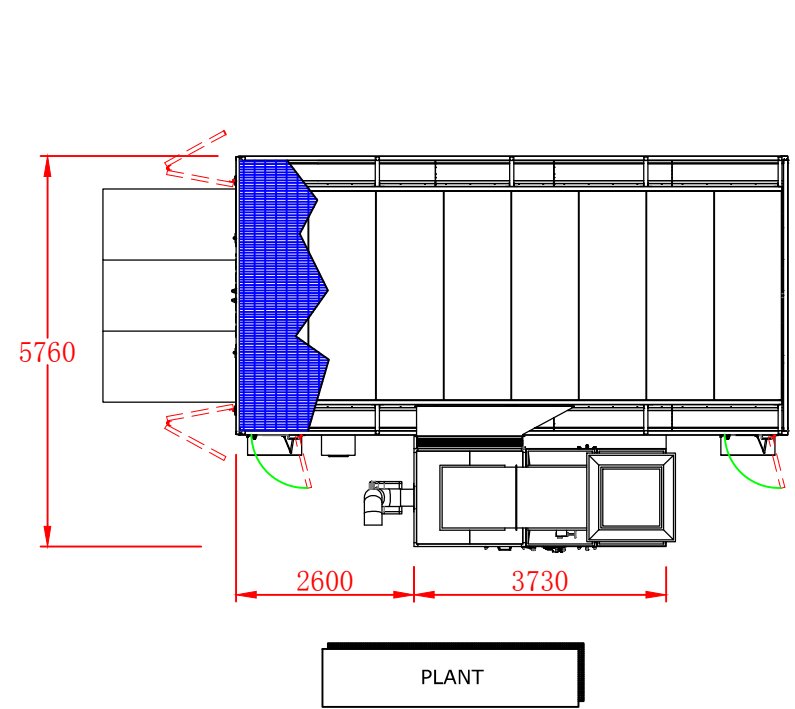

INFITECH [®]				Spray Booth IT-L8				Product Model		
								Part No.		
Designed		Date:		Material	Quantity	Weight	Scale	Unit	mm	
Drawn		Date:			1		1:1	Recision No.		
Checked		Date:								
Approved		Date:		View		Total Page	,Page	Description		